



10A 250V AC Qualified Type SDDJE Series

Type	Rocker		
Circuit arrangement	DPST		
Travel	3.4mm		
Operating force	6±3N		
Mounting method	Snap-in		
Terminal type	For Lead		
Frame	Without		
Marking (knob)	-, O mark		
C-UL-US	10AGP 250V AC		
SEMKO	6A/96A 250V~, 10(6)/250~		
VDE	6A/96A 250V~, 10(6)/250~		
BS	6A/96A 250V~, 10(6)/250~		
Ratings satisfying local electrical appliance and material safety law	125V 10A †		
Operating temperature range	-10°C to +55°C		
Rating	10AGP 250V AC, 6A/96A 250V~		
Electrical performance	Contact resistance	100mΩ max.	
	Insulation resistance	500MΩ min. 500V DC	
	Voltage proof	2,000V AC for 1 minute	
Mechanical performance	Terminal strength	50N for 1 minute (lead terminal) 5N for 1 minute (right-angle terminal)	
	Actuator strength	Operating direction	25N
		Perpendicular direction	25N
Durability	Operating life	10,000 cycles 10A 250V AC	

Environmental performance	Cold	-20°C 96h
	Dry heat	85°C 96h
	Damp heat	40°C, 90 to 95%RH 96h
Minimum order unit (pcs.)	Japan	400
	Export	2,000

Dimensions

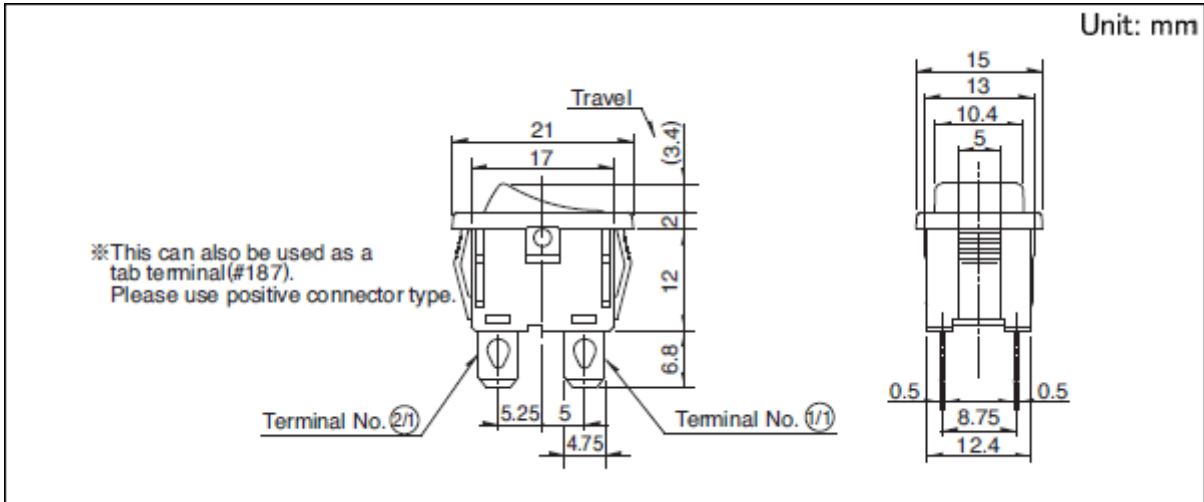

Mounting Hole Reference Size

Square-shaped Hole Unit:mm

Thickness of mounting board	Y ₁	Z
0.75 to 1.25	19.2 ⁰ _{-0.1}	12.9 ^{+0.1} ₀
1.25 to 2.00	19.4 ⁰ _{-0.1}	

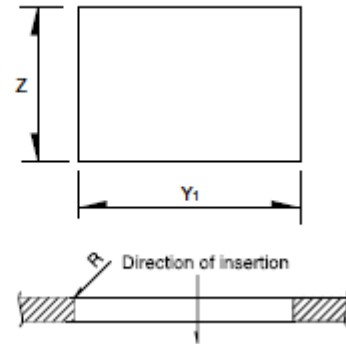

U-shaped Hole Unit:mm

Thickness of mounting board	Y ₂	Z
0.75 to 1.1	19.5 ⁰ _{-0.1}	12.9 ^{+0.1} ₀
1.1 to 1.7	19.7 ⁰ _{-0.1}	
1.7 to 2	19.9 ⁰ _{-0.1}	

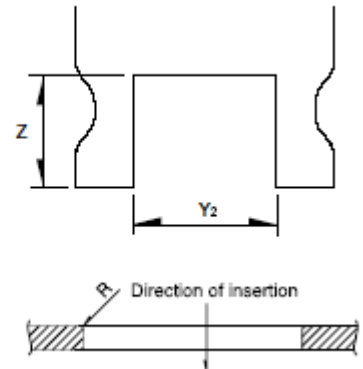

Verify the performance under actual product conditions before use.

Circuit Diagram

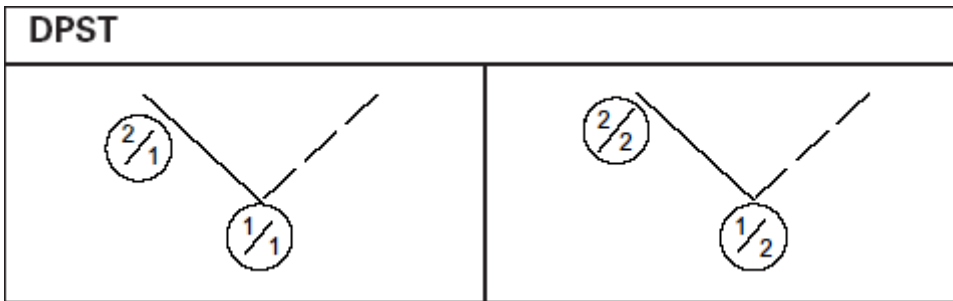

Marking (knob)

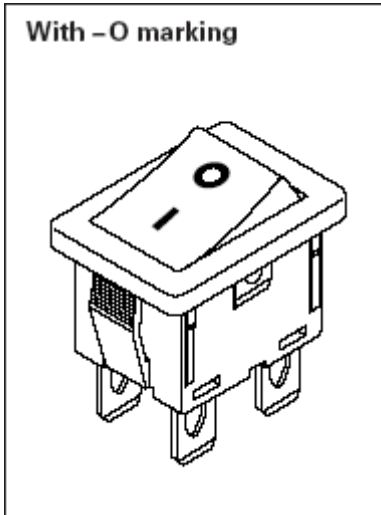

Packing Specifications

Tray

Number of packages 1 case / Japan (pcs.)	400
1 case / export packing	2,000
Export package measurements (mm)	411×328×379

Soldering Conditions

Reference for Hand Soldering

Soldering temperature	350±10℃
Soldering time	3+1/0s

Notes are common to this series/models.

1. This site catalog shows only outline specifications. When using the products, please obtain formal specifications for supply.
2. The lead terminals are also used as tab terminals (#187). (Use a positive lock connector type.)
3. The lead terminal type can be mounted onto a board. (Manual soldering required.)
4. Standard products apply Grade V-2 material (Flame Class). For Grade V-0 type please contact us.
5. Please place purchase orders per minimum order unit (integer).
6. Products other than those listed in the above chart are also available. Please contact us for details.